

AQUAHEAT CAPE
5 SENNA RD, KILLARNEY GARDENS,
MILNERTON, 7441
TEL: 0861 50 35 50
EMAIL: INFO@AQUAHEAT.COM



AQUAHEAT GAUTENG
UNIT 7, 126 ROAN CR, CORPORATE PARK NORTH,
MIDRAND, 1685
FAX: 0866 31 30 19
WEBSITE: WWW.AQUAHEAT.COM

TECHNICAL SPECIFICATIONS SF G/EVAP PREMIER SERIES

Model	SF	SF010P	SF015P	SF020P	SF030P	SF040P	SF050P	SF050/3P	SF060P	SF060/3P
HEATING CAPACITY	kW	4.5	6.8	9.2	13.8	18.2	22	22	26	26
	BTU/h	15300	23200	31400	47000	62000	75000	75000	88000	88000
HEATING POWER INPUT	kW	0.9	1.1	1.5	2.1	3	3.6	3.6	4.3	4.3
RUNNING CURRENT	A	4.1	5.1	6.7	10.4	13.4	16.1	5.4	25	8.7
POWER SUPPLY	V/Ph/Hz	230/1/50	230/1/50	230/1/50	230/1/50	230/1/50	230/1/50	230/1/50	380/3/50	380/3/50
COMPRESSOR QUANTITY	No	1	1	1	1	1	1	1	1	1
COMPRESSOR	Type	Rotary	Rotary	Rotary	Rotary	Rotary	Scroll	Scroll	Scroll	Scroll
HEAT EXCHANGER	Type	Titanium in PVC	Titanium in PVC	Titanium in PVC	Titanium in PVC	Titanium in PVC	Titanium in PVC	Titanium in PVC	Titanium in PVC	Titanium in PVC
FAN QUANTITY	Nr	1	1	1	1	1	2	2	2	2
FAN POWER INPUT	W	90	90	120	120	150	120 x 2	120 x 2	120 x 2	120 x 2
FAN ROTATE SPEED	RPM	850	850	850	850	850	850	850	850	850
FAN DIRECTION	Vertical / horizontal	Horizontal	Horizontal	Horizontal	Horizontal	Horizontal	Horizontal	Horizontal	Horizontal	Horizontal
NOISE	dB(A)	47	47	51	54	56	56	56	56	56
WATER CONNECTION	mm	50	50	50	50	50	50	50	50	50
WATER FLOW VOLUME	m3/h	1.5	2.2	3	4.5	6	7.5	7.5	9	9
WATER FLOW VOLUME	Lt/h	1500	2200	3000	4500	6000	7500	7500	9000	9000
WATER PRESSURE DROP	kPa	4	4	6	6	20	20	20	20	20
UNIT DIMENSIONS	Length	746	746	956	956	1115	1002	1002	1002	1002
	Width	264	264	334	334	425	396	396	396	396
	Height	570	570	600	600	870	1251	1251	1251	1251
SHIPPING DIMENSIONS	Length	846	846	1040	1040	1220	1130	1130	1130	1130
	Width	310	310	415	415	480	485	485	485	485
	Height	590	590	615	615	880	1270	1270	1270	1270
NET WEIGHT	kg	35	35	51	51	84	117	117	119	119
SHIPPING WEIGHT	kg	42	42	55	55	95	136	136	137	137
CIRCUIT BREAKER	Slow curve	5	10	10	15	15	20	10TP	30	10TP
	Normal	10	10	15	20	25	30	15TP	35	15TP

AQUAHEAT CAPE
 5 SENNA RD, KILLARNEY GARDENS,
 MILNERTON, 7441
 TEL: 0860 50 35 50
 EMAIL: INFO@AQUAHEAT.COM



AQUAHEAT GAUTENG
 UNIT 7, 126 ROAN CR, CORPORATE PARK NORTH,
 MIDRAND, 1685
 FAX: 0866 31 30 19
 WEBSITE: WWW.AQUAHEAT.COM

Model: SF010P + SF015P in mm

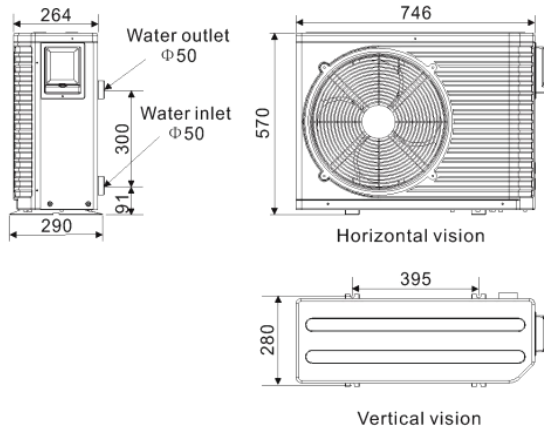

Model: SF020P + SF030P in mm

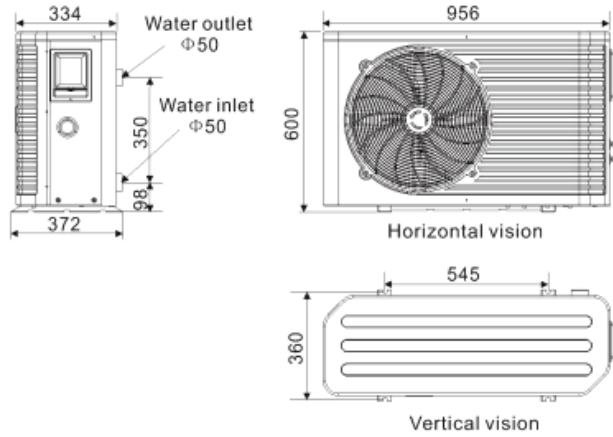

Model: SF040P in mm

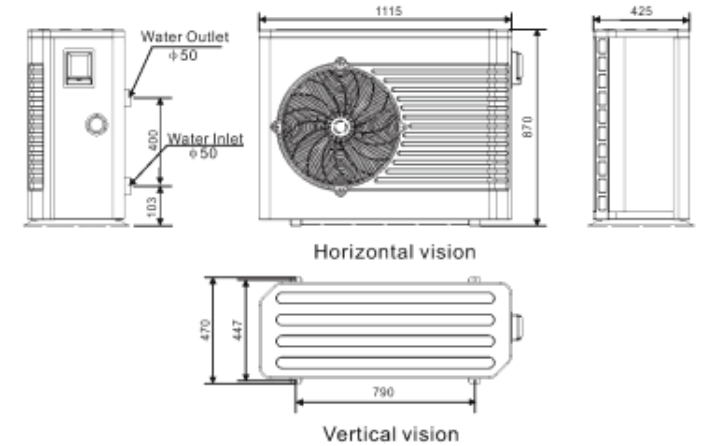

Model: SF050P + SF060P in mm (SINGLE AND THREE PHASE)

